

VERSA-LOK[®] MOSAIC

PALLET OVERVIEW

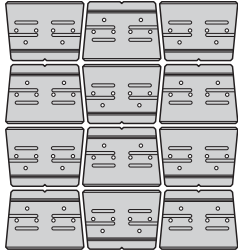

STANDARD
 24 units / pallet
 16 sq. ft. / pallet
 2 layers / pallet
 2,100 lbs. / pallet



ACCENT
 48 units / pallet
 16 sq. ft. / pallet
 3 layers / pallet
 1,795 lbs. / pallet

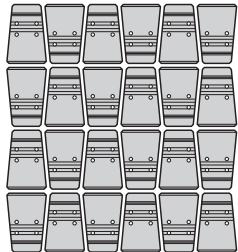

COBBLE
 48 units / pallet
 16 sq. ft. / pallet
 2 layers / pallet
 1,872 lbs. / pallet

SPECIFICATIONS



STANDARD
 16" x 12" x 6"
 86 lbs. / unit
 1.5 units / sq. ft.



ACCENT
 12" x 12" x 4"
 37 lbs. / unit
 3 units / sq. ft.

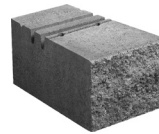

COBBLE
 8" x 12" x 6"
 38 lbs. / unit
 3 units / sq. ft.

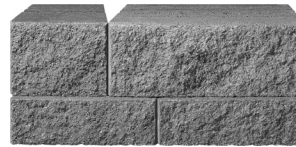

MOSAIC PANEL
 24" x 12" x 10"
 PANEL = 1 STANDARD,
 1 COBBLE, 2 ACCENT

LAYING PATTERNS

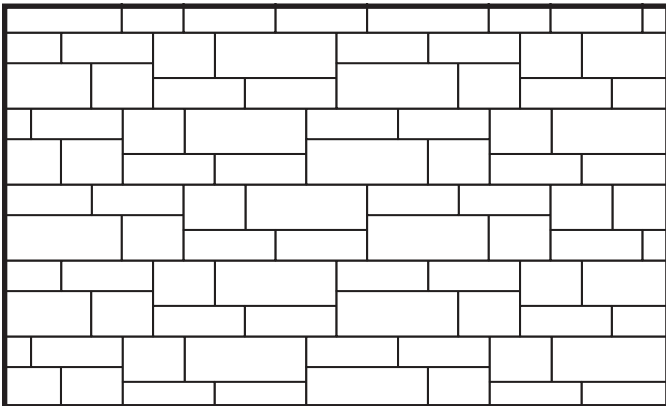

MOSAIC PINNING DETAIL

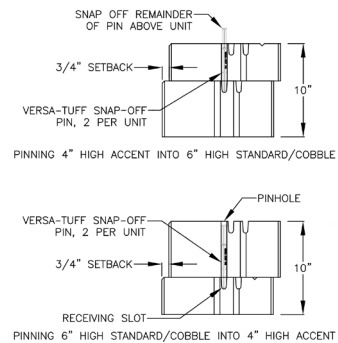

NOTES



**DRYCAST
 WARRANTY**



**OUTDOOR
 LIVING**



**WALLS &
 COLUMNS**

COLOR SWATCHES AVAILABLE AT LAMPUS.COM • ALL WEIGHTS ARE APPROXIMATE.

APPLICATIONS